

Ultra-Low Phase Noise Multioutput Frequency Reference in 19" Rack Mountable Appliance 1U Form Factor

Product Data Sheet

Features

- Ultra-Low Phase Noise (ULPN)
- 10 MHz, 100 MHz, and 800 MHz Outputs
- 10 MHz and 100 MHz internal SC-cut OCXOs

Applications

- 5G device testing
- Radar
- COTS/Dual use

Frequency Adjustment

Mechanical

Outputs on Front Panel

- 10 MHz OUT SMA Female
- 100 MHz OUT SMA Female
- 800 MHz OUT SMA Female

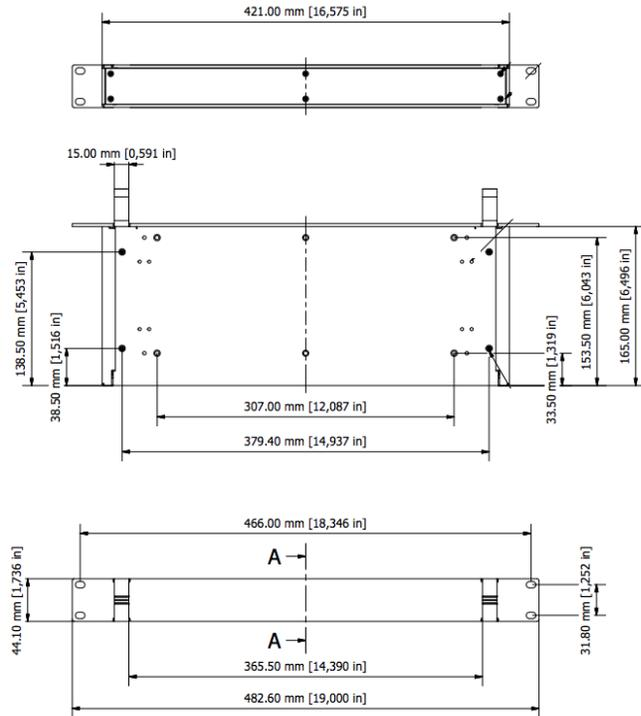

Mechanical Dimensions

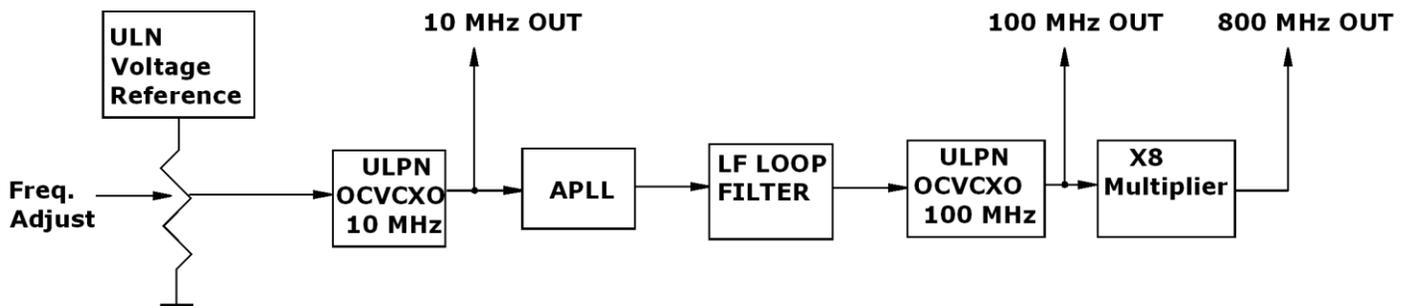

Rev. -

Front Panel



Back Panel



Specifications:

Parameter	Symb	Condition	Min	Typ	Max	Unit	Note
Absolute Maximum Ratings							
Power supply	Vp		90		260	V AC	
Operating Temp.	To		10		45	°C	
Storage temper.	Ts		0		70	°C	
Electrical							
Frequency stability	$\Delta F/F$	vs. Temp.	From ± 2.0			ppb	See chart below
		vs. Supply		0.1	0.2	ppb/5% Vcc	
		vs. Load			0.5	ppb/5% load var.	
Aging		per day per year, first year second year 10 years		2E-10 2E-8 1E-8 1E-7			after 30 days
Initial calibration				± 50		ppb	
Trim range				± 0.2		ppm	
Allan Deviation		0.1 s		2E-13	3E-13		Static and benign conditions
		1 s		4E-13	5E-13		
		10 s		2E-12	4E-12		
		100 s		5E-12	7E-12		
Output Frequencies	F10			10.000		MHz	SMA
	F100			100.00			SMA
	F800			800.00			SMA
SSB Phase Noise (achieved after 10 minutes warm-up)	$\mathcal{L}(\Delta f)$	0.01 Hz		-46		dBc/Hz	10 MHz output
		0.1 Hz		-89			
		1 Hz		-120			
		10 Hz		-150			
		100 Hz		-162			
		1 KHz		-165			
		10 KHz		-168			
100 KHz		-170					
		10 Hz		-120			100 MHz output
		100 Hz		-130			

		1 KHz 10 KHz 100 KHz		-160 -175 -180			
		10 Hz 100 Hz 1 KHz 10 KHz 100 KHz		-100 -110 -140 -155 -160			800 MHz output
Power Requirements	P	IEC320 on the back	100 to 250 V AC 50/60 Hz		V AC		
Spectral Purity		Subharmonics Spurious Harmonics		-50 -35	-40 -80 -30	dBc	@ 0.1, 0.8 GHz Outputs. Either output
Load	Internally AC-coupled 50 Ohm						All Outputs
Output Waveform	Sinewave						
Output Power			+10	+13		dBm	All outputs
Load	Internally AC coupled 50 Ohm (Sinewave) 10K Ohm//15pf (CMOS/TTL)						Unused outputs must be terminated
Warm-up time	τ	To 0.1 ppm accuracy		5	8	minutes	

Environmental and Mechanical

Operating temp. range	+10°C to +45°C
------------------------------	----------------

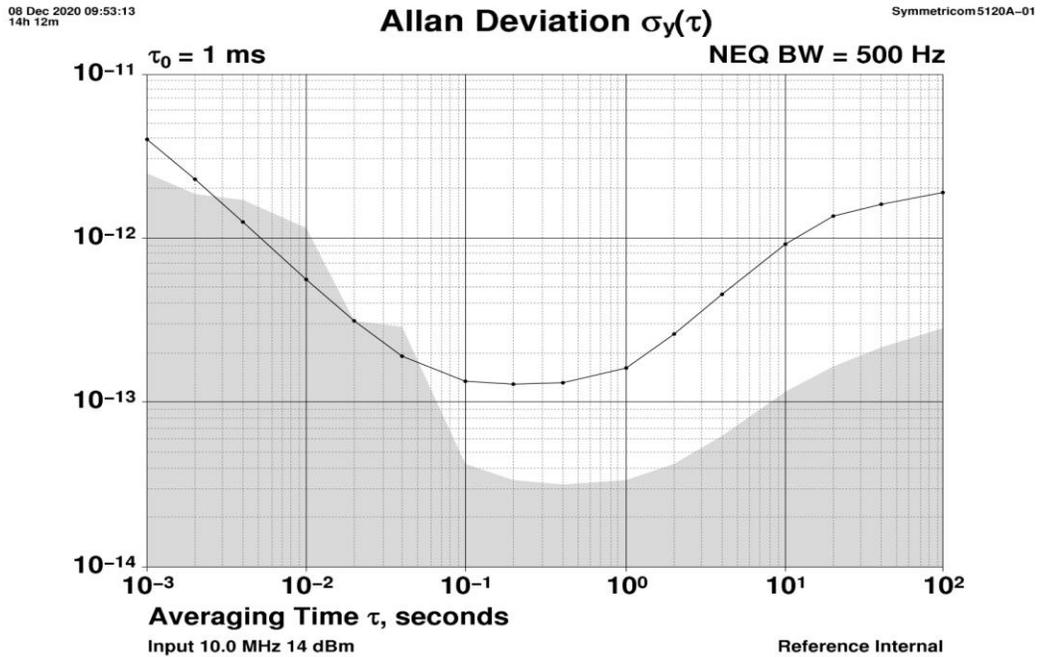
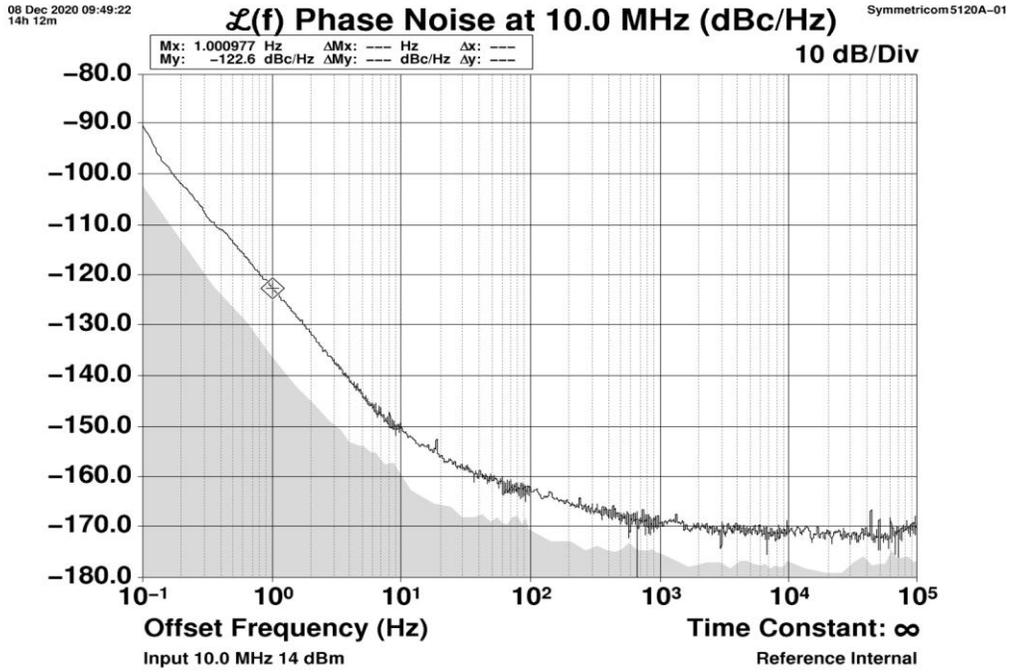

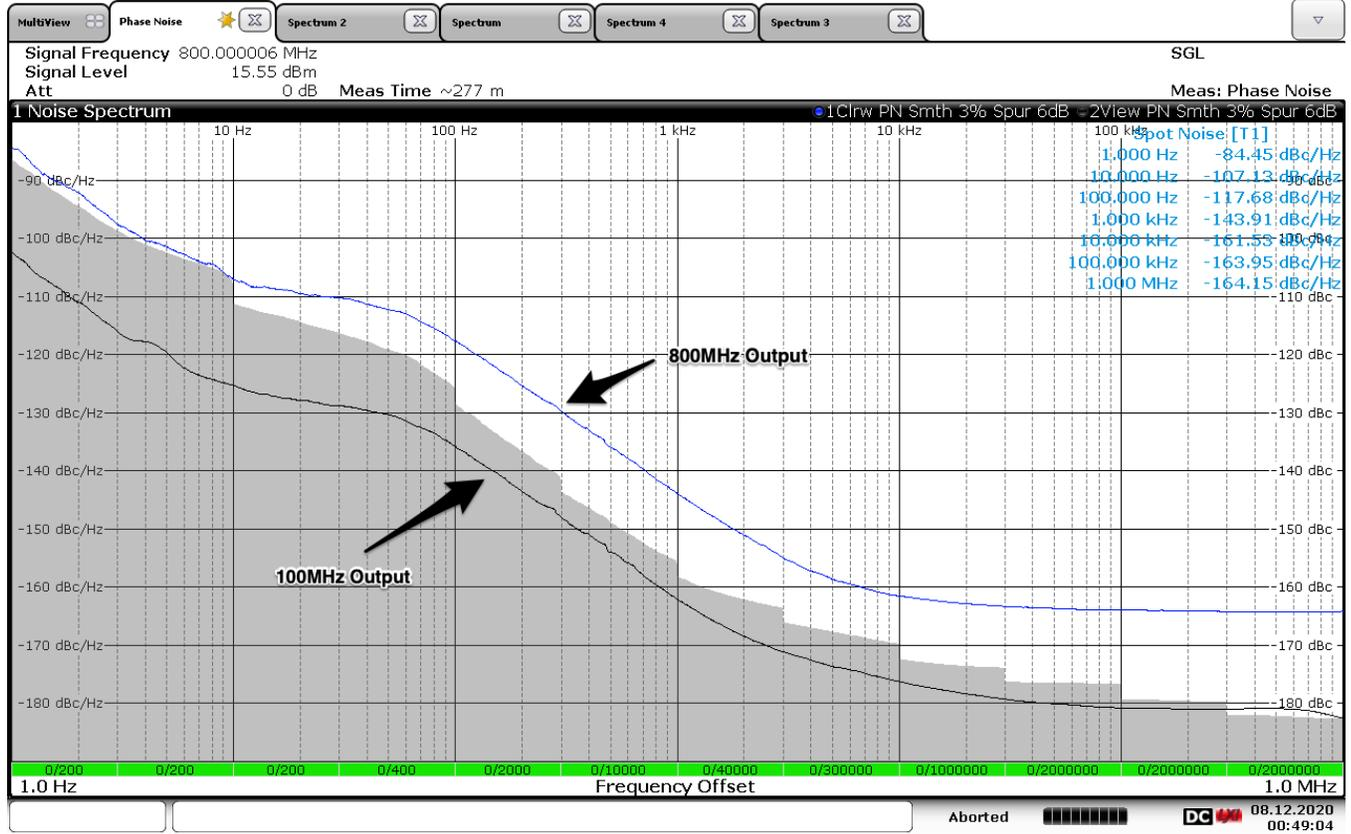

00:49:05 08.12.2020



**FREQUENCY
CONTROLS, INC.**